

1.855.882.2886

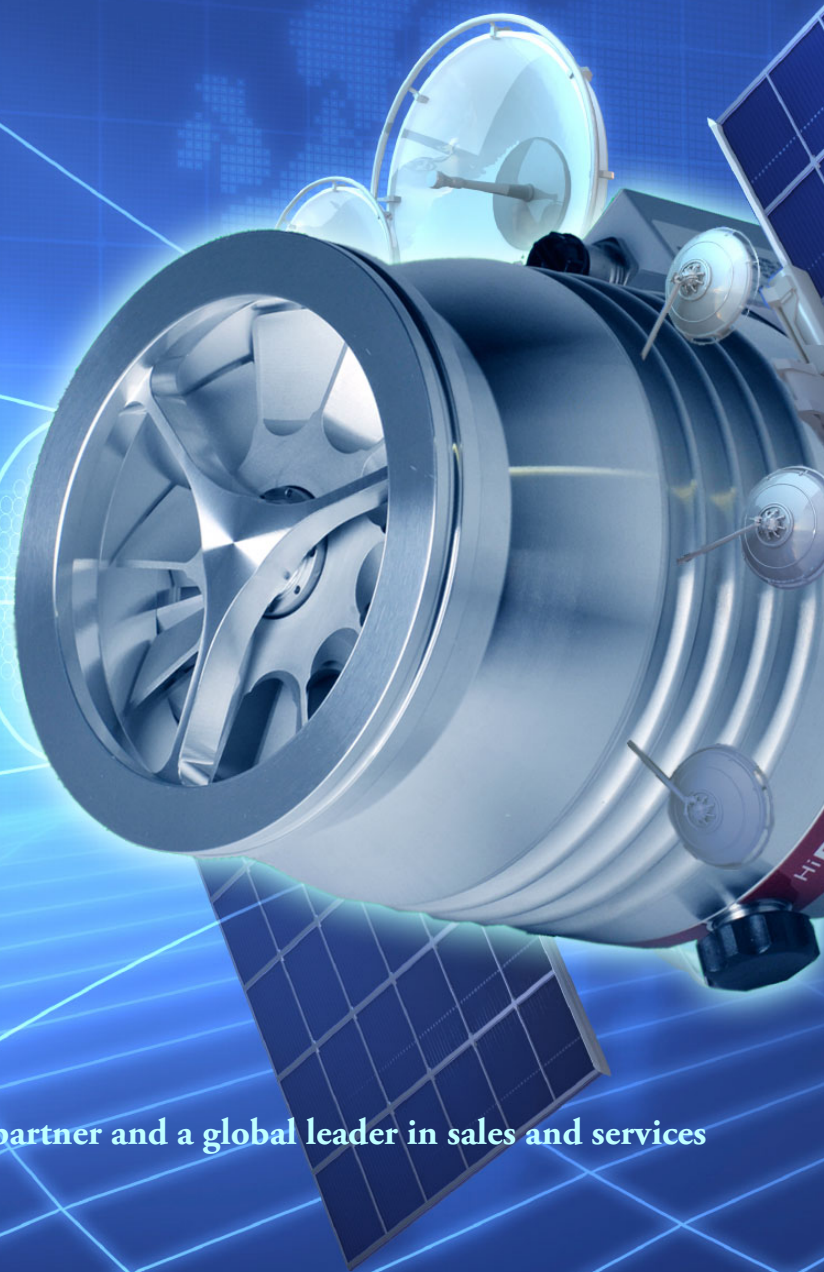

# AJVS

[www.ajvs.com](http://www.ajvs.com)



A&J Vacuum Services is your highly qualified partner and a global leader in sales and services of your High Vacuum equipment.

A&J Vacuum Services, Inc.  
790 Bloomfield Ave., Suite B3  
Clifton, NJ 07012, USA  
Tel: 973-249-0854  
Fax: 973-249-0855  
Website: [www.ajvs.com](http://www.ajvs.com)

Customer Service: [info@ajvs.com](mailto:info@ajvs.com)  
Sales Inquiries: [sales@ajvs.com](mailto:sales@ajvs.com)  
Service Inquiries: [service@ajvs.com](mailto:service@ajvs.com)  
Technical Assistance: [tech@ajvs.com](mailto:tech@ajvs.com)  
Order Status: [tracking@ajvs.com](mailto:tracking@ajvs.com)

***Operating Instructions***

***TMH 064 / TMU 064***  
***TMH 065 / TMU 065***

---

***Turbomolecular Drag Pumps***



	Page		Page
<b>1. Safety Instructions .....</b>	<b>3</b>	<b>4. Operations.....</b>	<b>9</b>
1.1. For Your Orientation.....	3	4.1. Before Switching ON.....	9
1.2. Pictogram Definitions.....	3	4.2. Switching ON.....	9
<b>2. Understanding The Pumps</b>		Reset .....	9
<b>TMH/TMU 064, TMH/TMU 065 .....</b>	<b>4</b>	4.3. Heating (Only Pumps With Heating Sleeves).....	9
2.1. Main Features .....	4	4.4. Switching OFF And Venting.....	9
2.2. Differences Between The Pump Types .....	4	4.5. Shutting Down For Longer Periods .....	10
<b>3. Installation.....</b>	<b>5</b>	<b>5. What To Do In Case Of</b>	
3.1. Preparations For Installation .....	5	<b>Breakdowns ? .....</b>	<b>10</b>
3.2. Assembling The Pump, Connecting The		<b>6. Maintenance.....</b>	<b>11</b>
High Vacuum Side .....	5	6.1. Replacing The Lubricant Reservoir.....	11
Fitting The Splinter Shield .....	6	<b>7. Service.....</b>	<b>12</b>
3.3. Connecting The Fore-Vacuum Side.....	6	<b>8. Technical Data.....</b>	<b>13</b>
3.4. Connecting The Cooling Unit .....	6	8.1. Dimensions Diagram .....	14
Water Cooling (Accessory).....	6	<b>9. Spare Parts .....</b>	<b>14</b>
Air Cooling (Accessory).....	7	<b>10. Accessories .....</b>	<b>16</b>
3.5. Connecting The Casing Heating Unit .....	7	<b>Declaration of Contamination.....</b>	<b>17</b>
3.6. Connecting The Venting Valve .....	8	<b>Manufacturer's Declaration..... (last page)</b>	
3.7. Connecting The Electronic Drive Unit.....	8		
3.8. Connecting The Sealing Gas Valve .....	8		

# 1. Safety Instructions

- ☞ Read and follow all the instructions in this manual.
- ☞ Inform yourself regarding:
  - Hazards which can be caused by the pump;
  - Hazards which can arise in your system;
  - Hazards which can be caused by the medium being pumped.
- ☞ Avoid exposing any part of your body to vacuum.
- ☞ Comply with all safety and accident prevention regulations.
- ☞ Check regularly that all safety requirements are being complied with.
- ☞ Do not operate the pump with open high vacuum flange.
- ☞ Do not carry out any unauthorised conversions or modifications on the pump.
- ☞ When returning the pump to us please note the shipping instructions.
- ☞ Use at least four bracket screws to connect the high vacuum flange (ISO-flange).
- ☞ Fix down the pump in accordance with the instructions on installation.
- ☞ Do not disconnect the pump cable during operations.
- ☞ When the pump is open, disconnect the electronic drive unit from the mains.
- ☞ After switching off the pump, disconnect the electronic drive unit only once the rotor is at rest.
- ☞ When working on the pump, only open the high vacuum flange once the rotor is at rest.
- ☞ When using sealing gas, limit the pressure in the hose connection to 2 bar via the overflow valve.
- ☞ If a heater is in use temperatures of up to 120 °C can be present in the area of the high vacuum flange. Take care to avoid burns !
- ☞ During operations, temperatures of up to 65 °C can arise in the lower part of the turbopump. Take care to avoid burns!
- ☞ Keep leads and cables well away from hot surfaces (> 70 °C).

Modifications reserved.

## 1.1. For Your Orientation

### Instruction in the text

➔ Working instruction: here, you have to do something.

### Symbols used

The following symbols are used throughout in all illustrations.

- Ⓜ High vacuum flange
- Ⓥ Fore-vacuum flange
- Ⓧ Venting connection
- Ⓝ Cooling water connection
- Ⓡ Air cooling
- Ⓡ Electric connection
- Ⓢ Sealing gas connection

### Position numbers

The same pump and accessory parts have the same position numbers in all illustrations.

## 1.2. Pictogram Definitions



Danger of burns from touching hot parts.



Danger of an electric shock.



Danger of personal injury.



Danger of damage to the pump or to the system.



Danger of injury from rotating parts.

## 2. Understanding The Pumps TMH/TMU 064 und TMH/TMU 065

### 2.1. Main Features

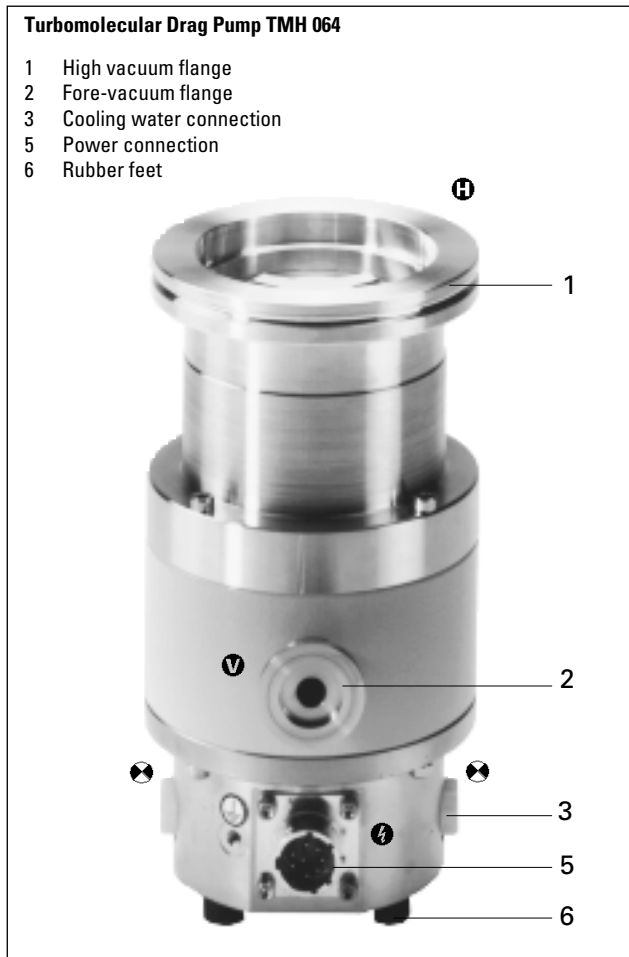

#### Cooling

Standard: Convection cooling.

Alternative: Air or water cooling as an accessory.

Integrated excess temperature safety feature:  
Electronic drive unit reduces rotor rotation speed to zero.

#### Bearings

High vacuum side: Wear free permanent magnetic bearing.

Fore-vacuum side: Oil circulatory lubricated bearings with ceramic balls.

#### Proper use

- The Turbomolecular Pumps may only be used for the purpose of generating vacuum.
- The turbopumps may only be used to pump those media against which they are chemically resistant. For other media the operator is required to qualify the pumps for the processes involved.
- If the process produces dust, the maintenance intervals must be specified accordingly and sealing gas must be used.
- The turbomolecular pump may only be operated with a PFEIFFER Electronic Drive Unit and relevant cables.
- The turbopump must be connected to a backing pump in accordance with Section 3.3.

#### Improper use

The following is regarded, inter alia, as improper:

- The pumping of explosive or corrosive gases.
- Operating the pumps in areas where there is a danger of explosion.
- The pumping of gases and vapours which attack the materials of the pumps.
- The pumping of corrosive gases without sealing gas.
- The pumping of condensating vapours.
- Operations involving impermissibly high levels of gas loads.
- Operations with improper gas modes.
- Operations involving too high levels of heat radiation power (see Section 8. "Technical Data").
- The use of accessories which are not named in this manual or which have not been agreed by the manufacturer.

Improper use will cause all claims for liability and guarantees to be forfeited.

### 2.2. Differences Between The Pump Types

Feature	TMH 064 TMH 064	TMU 064 TMU 065
High vacuum flange	ISO-K	CF-F
High vacuum seal	Viton	Metal
Attainable final pressure	$< 1 \cdot 10^{-8}$ mbar (without baking-out)	$< 1 \cdot 10^{-10}$ mbar (with baking-out)

## 3. Installation

### 3.1. Preparations For Installation



Do not carry out any unauthorised conversions or alterations to the turbopump.

- The maximum permissible rotor temperature of the pump is 90 °C. If the vacuum chamber or parts in the vacuum chamber are heated must be fitted if necessary, suitable shielding in the vacuum chamber before the turbopump (constructional suggestions available on request).
- Only remove the blank flange from the high and fore-vacuum side immediately before connection.
- On Turbopumps the lubricant reservoir is already fitted and filled.
- Where magnetic fields of > 4 mT are involved suitable shielding must be provided (available on request).
- If the pump is baked out, the heating sleeve and the body of the pump must be insulated to prevent burns from accidental contact.
- In the event of a sudden standstill of the rotor, torques of up to 260 Nm (TMH/U 064) and 270 Nm (TMH/U 065) can arise and these must be taken up by the turbopump and frame. Pumps must be anchored as follows:
  - ISO flange with 4 bracket screws, or
  - CF flange with the complete set of M8 screws, or
  - Underside of the pump with 4 screws M5, screws quality 8.8.

### 3.2. Installing The Pump, Connecting The High Vacuum Side

#### Important

The utmost cleanliness must be observed when fitting all high vacuum parts. Unclean components prolong the pumping time.

#### Using the splinter shield

The use of a splinter shield in the high vacuum flange protects the turbopump against foreign bodies coming from the vacuum chamber but does reduce the volume flow rate of the pump by approximately 15%.

For fitting splinter shields please refer to "Fitting the splinter shield"

The high vacuum side can be flanged directly to the vacuum chamber or via a bellows or a vibration compensator (accessory).

#### Connecting via a bellows

If the high vacuum side is to be flanged via a bellows, the turbopump must be secured for example via the holes on the underside of the turbopump (see "Dimensions")

The fastening must be able to withstand the torque referred to in Section 3.1.

#### Connecting via a vibration compensator



The maximum permissible temperature at the vibration compensator is 100 °C.

Where a vibration compensator is in use, a freely suspended turbopump can be flanged onto the vacuum chamber. Additional fastening is unnecessary.

#### Directly flanging the pump

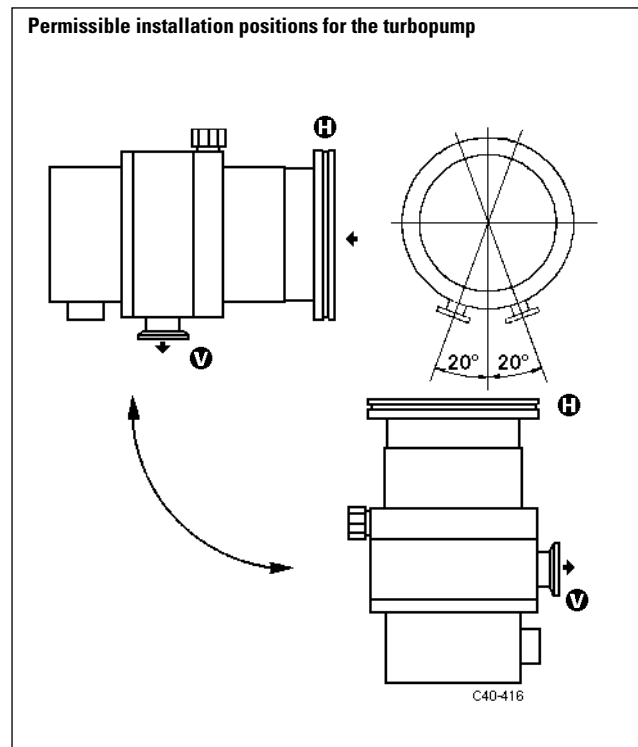

The maximum loading capacity of the high vacuum flange is 200 N (equivalent to 20 kg). Asymmetric loading on the high vacuum flange must be avoided.

With horizontal pump installation and oil-sealed backing pumps (e.g. rotary vane pumps) the fore-vacuum flange of the turbopump must be aligned vertically downwards (maximum deviation  $\pm 20^\circ$ ), otherwise the turbopump could become dirty.



No forces from the piping system must be allowed to act on the pump where turbopumps are anchored. Suspend or support all pipes to the pump.

## Fitting The Splinter Shield

Insert the splinter shield in the high vacuum flange in such a way that the corrugation of the strainer points outwards.

- ➔ Bend the clamping lugs slightly outwards so that subsequently the splinter shield is seated firmly in the high vacuum flange (to avoid noise).
- ➔ Insert the splinter shield in the high vacuum flange while pressing the clamping lugs slightly inwards.
- ➔ Press the outer ring of the splinter shield up to the limit stop point in the high vacuum flange.

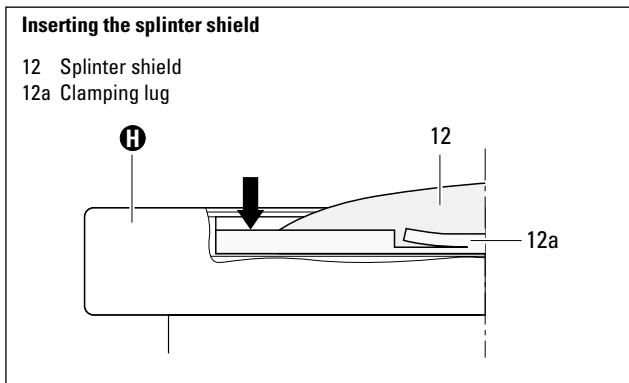

### 3.3. Connecting The Fore-Vacuum Side

Backing pump: Vacuum pressure  $\leq 5$  mbar  
 Recommendation: Oil-Free Diaphragm Pump or Rotary Vane Vacuum Pumps from the PFEIFFER range (note installation position, turbopump, see Section 3.2.).

#### Connecting the backing pump

All connections of the fore-vacuum line: with the usual small flange components or hose screw connections.



Be sure to conduct away the exhaust gases from the backing pump. Do not reduce the free cross section of the fore-vacuum flange with following components.



The exhausted process gases and vapours can represent a health hazard and can also be environmentally damaging. Comply with all the gas manufacture's safety instructions.

- ➔ Fit the vacuum safety valve in the fore-vacuum line (in PFEIFFER rotary vane vacuum pumps already integrated). This prevents vacuum chamber venting via the backing pump.
- ➔ With rigid pipe connections: Fit bellows in the connecting line to reduce vibration.
- ➔ Backing pump power connection: See operating instructions for the electronic drive unit.

#### Connecting the backing pump

- 21 Backing pump  
22 Vacuum safety valve  
23 Suction line

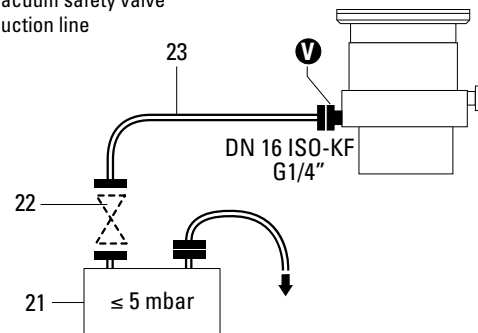

### 3.4. Connecting The Cooling Unit

The turbopump is convection-cooled as standard. Where ambient temperatures exceed 30 °C or with heated systems, the pump should be operated with air or water cooling.

Water cooling is mandatory where temperatures exceed 35 °C.

#### Water Cooling (Accessory)

See "Accessories" for the cooling water parts set.

#### Connecting parts set for cooling water

- 16 USIT ring  
18 Hose nozzle  
19 Hollow screw

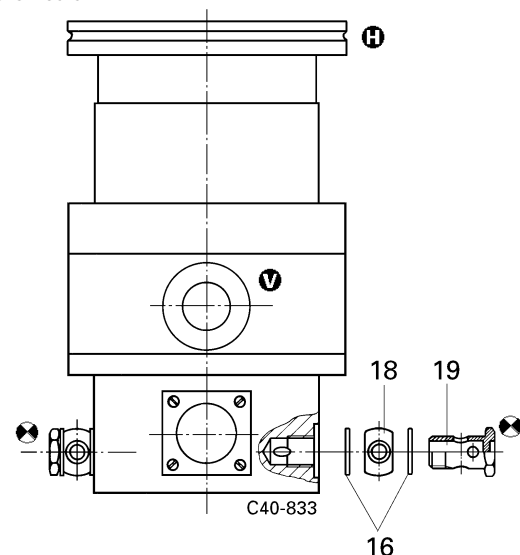

Cooling water either

- From the cooling water mains, or
- from Recycled Water Cooling Unit TZK with closed circuit.

#### Cooling water from the cooling water mains

Cooling water must be filtered to prevent deposits forming in the pump.

Minimum cooling water requirements:

Mechanically clean, optically clear, no turbidity, no sediment, chemically neutral, temperature > dew point.

Oxygen content:	max. 4 mg/kg
Chloride content:	max. 100 mg/kg
Carbonate hardness:	max. 10 °dH
Potassium permanganate consumption:	max. 10 mg/kg
Carbon dioxide:	Undetectable
Ammonia:	Undetectable
pH-value:	7 – 9
Fore-line over pressure:	max. 6 bar
Minimum flow rate at gas load max.:	50 l/h bei 15 °C

### Connecting to the water mains

- ➔ Fit dirt trap (accessory) in the fore-line.
- ➔ Using circlips, connect fore-line to one of the two cooling water connections.
- ➔ Fit Cooling Water Monitor TCW 002 (accessory) in the return line.
- ➔ Connect return line to the other turbopump cooling water connection.
- ➔ Tighten all circlips and ensure hose lines are seated firmly.
- ➔ Tighten the hollow screws on the cooling water connection to a torque of 20 Nm.

### Cooling from the water mains

- 3 Cooling water connection
- 31 Fore-line
- 32 Return line
- 33 Dirt trap
- 34 Cooling Water Monitor TCW 002

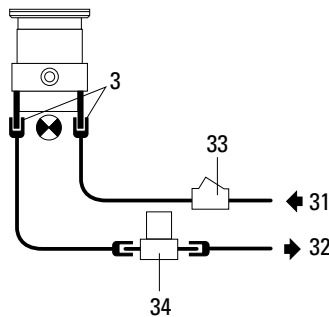

### Cooling with the recycled Water Cooling Unit TZK (Accessory)

#### Connecting to the TZK

A dirt trap in the pipeline is not permissible.  
All other steps as for connection to the water mains.

### Cooling with the recycled Water Cooling Unit TZK

- 3 Cooling water connections
- 34 Cooling Water Monitor TCW 002 in the return line
- 35 Recycled Water Cooling Unit TZK

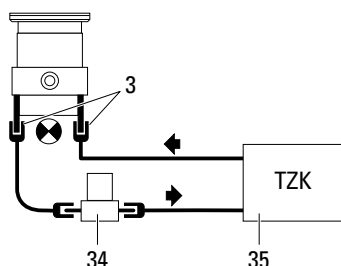

## Air Cooling (Accessory)

See "Accessories" for air cooling parts set.



Air cooling permissible only if ambient temperature < 35 °C.  
Ensure adequate air circulation and ventilation.

### Fitting the air cooling

- ➔ Place turbopump on its high vacuum flange (blank flanged so that the sealed surface is not damaged).
- ➔ Unscrew rubber feet from the base of the pump.
- ➔ Screw air cooling onto the holder with 4 M5 screws and spring washers onto the turbopump. The fan must be parallel to the axis fore-vacuum connection - venting connection. See illustration below.

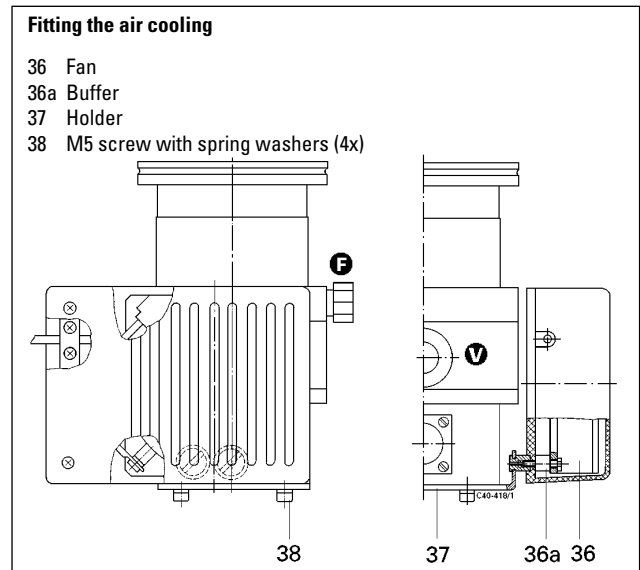

### Power connection, air cooling

Please see the operating instructions for the Electronic Drive Unit TCP 015.

## 3.5. Connecting The Casing Heating Unit

The attainment of final pressures is accelerated when turbopumps and vacuum chambers are baked out.

The heating duration is dependent on the degree of dirt and on the required final pressure level. The heating duration should be at least 4 hours.

- ➔ Secure heating sleeve beneath high vacuum flange.



High temperatures are generated when turbopumps and vacuum chambers are baked out. There is a danger of burns resulting from touching hot parts, even after the casing heating has been switched off.

Ideally, the heating sleeve, pump casing and vacuum chamber should be insulated during installation. Do not touch the heating sleeve, pump casing and vacuum chamber during the baking out process.

### 3.6. Connecting The Venting Valve

- The venting valve provides automatic venting in the event of a power failure and switching off.

Venting Valve	Control Unit	Electronic Drive	Venting Procedure After Switch OFF Or Power Failure
TSF 010	not required	independent	Immediate; Venting valve remains open
TSF 012	not required	TCP 015/ 380/121	Delayed (venting begins at approx. 20% of the rated rotation speed) venting valve remains open
TVF 012	TCF/TCV 103	TCP 380/121 (not with TCP 015)	Delayed: adjustable (with TCS 304)

#### Fitting the venting valve

Please refer to the operating instructions of the respective unit. Use Adapter PM 033 737-T where flange size DN 10-KF is involved.

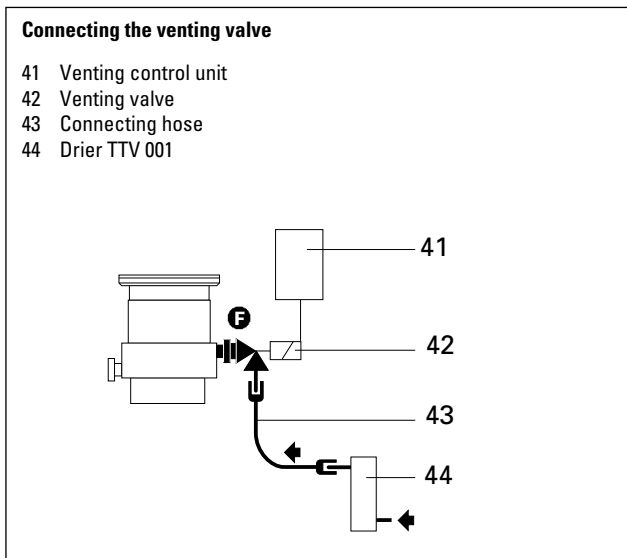

#### Power connection

Please refer to the operating instructions of the respective unit.

### 3.7. Connecting The Electronic Drive Unit



Voltages of >100 V can be present on the open electrical contacts on a slowing down pump. There is danger of an electrical shock if the contacts are touched.

Disconnect the plug to the electronic drive unit only once the pump is completely at rest and the electronic drive unit has been disconnected from the mains.

- ➔ Plug in connecting cable between the electronic drive unit and the turbopump. For details please see the operating instructions for the electronic drive unit.

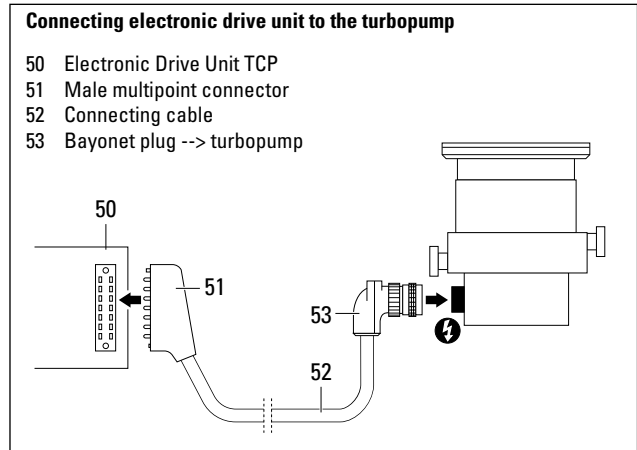

### 3.8. Connecting The Sealing Gas Valve

To protect the pump, particularly where corrosive or dust producing processes are involved, it is necessary to use sealing gas. Connection is made via the sealing gas valve (please see "Accessories").

Please refer to Operating Instructions PM 800 229 BE for details on installing the sealing gas valve and adjusting the sealing gas flow.

Please refer to Section 8.1. "Dimensions Diagram" for the sealing gas connection.

## 4. Operations

### 4.1. Before Switching ON



Turbopump rotors rotate at high speed. When the high vacuum flange is open there is a danger of injury and of damage to the pump caused by objects falling into the pump.

Therefore never operate the pump with open high vacuum flange.

- ➔ With water cooling: Open cooling water supply and check flow.

### 4.2. Switching ON

- ➔ Switch on the turbopump with switch S1 on the power pack unit.

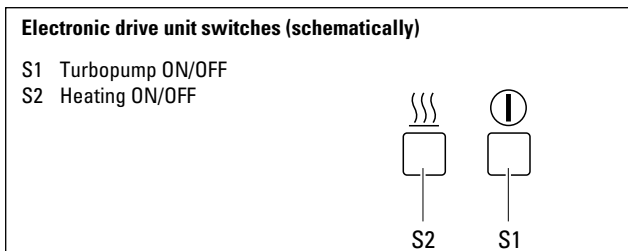

- With air cooling, the cooling fan is also switched on by the electronic drive unit.
- If Pumping Station Control Unit TCS 303/304 is involved, turbopump, backing pump and the water recycling unit (if fitted) are started together with switch S1 on the electronic drive unit.



Take care when pumping hazardous gases. Comply with all the gas manufacturer's safety instructions.

### Reset

#### TMH/TMU 064/065 with TCP 015:

When the TCP 015 detects a fault, the motor power is switched off. After the fault has been corrected, the pump does **not** accelerate automatically. The "reset" command required for this may be executed by:

- ➔ Switching off via S1 for a time  $\geq 5$  seconds.
- ➔ Connecting the remote "Fault reset" input, X5/b6 to X5/z2 (0 volt) for a time  $\geq 5$  seconds via an external switch.
- ➔ Transmitting a corresponding command via the RS 232 C interface.

#### TMH/TMU 065/064 with TCP 121 or TCP 380:

In the event of malfunction, the voltage supply of the motor is switched off via the contact K2. The reset function is activated by:

- ➔ Disconnecting the mains voltage for a time  $\geq 2$  seconds, e.g. by pressing the mains switch S1.
- ➔ Operating an externally connected "reset" pushbutton S3 for a time  $\geq 2$  seconds.

#### Please note:

In the "reset" function is activated via an external reset pushbutton, the TCP must be energized.

### 4.3. Heating (Only Pumps With Heating Sleeves)

The heating period is dependent on the level of contamination and the required final pressure. Heat for at least four hours.

- ➔ Switch on turbopump heating via switch S2 on the electronic drive unit.

Please take account of the notes in Section 3.5.

### 4.4. Switching Off And Venting

To avoid contamination occurring when switching off, the pump should be vented with dry venting gas before shut-down.

- ➔ Close vacuum safety valve in the fore-vacuum line.
- ➔ Switch off both turbopump and backing pump at the same time with switch S1 on the electronic drive unit.
- ➔ Open locking screw or venting valve in the venting connection (with PFEIFFER venting valves and pertinent control units the turbopump is vented automatically).
- ➔ With water cooling: Shut off water supply.



The minimum venting time to atmospheric pressure is 30 seconds.

#### 4.5. Shutting Down For Longer Periods



Vacuum pumps are sometimes used to pump aggressive or hazardous gases. There is a danger of personal injury resulting from coming into contact with process gases. Before removing a turbopump from the system, first:

- Vent the turbopump with a neutral gas or dry air;
- Ensure that there is no residual process gas in the system nor in the supply lines.

If the turbopump is to be shut down for more than a year:

- ➔ Remove turbopump from the system.
  - ➔ Replace lubricant reservoir (see Section 6.1.).
- Please note:** Lubricant TL 011 must no longer be used after **2 years** of non operations.

- ➔ Close high vacuum flange and evacuate pump via the fore-vacuum flange.
- ➔ Vent turbopump via the venting connection with nitrogen or dry air.
- ➔ Close fore-vacuum and venting connections by blank flanging.
- ➔ Place the pump vertically on its rubber feet.
- ➔ In rooms with moist or aggressive atmospheres, the turbopump must be air-sealed in a plastic bag together with a bag of dessicant, e.g. silicagel.

**Important:**

If the pump has been shut down for **3 years** a bearing change must be carried out (please get in touch with PFEIFFER service).

## 5. What To Do In Case Of Breakdowns?

Problem	Possible Cause	Remedy
Pump doesn't start	<ul style="list-style-type: none"> <li>• Power supply interrupted</li> </ul>	<ul style="list-style-type: none"> <li>• Check fuse in the electronic drive unit</li> <li>• Check plug contacts on the pump and the electronic drive unit</li> <li>• Check supply lines</li> </ul>
Pump doesn't attain rated rotation speed; Pump cuts out during operations	<ul style="list-style-type: none"> <li>• Fore-vacuum pressure too high</li> <li>• Leak or too much gas</li> <li>• Rotor stiff because bearing defective</li> <li>• Run-up phase in the Electronic Drive Unit TCP too short</li> <li>• Thermal overloading caused by                             <ul style="list-style-type: none"> <li>– Water cooling: Flow not safe guarded</li> <li>– Air cooling: Air supply restricted</li> <li>– Fore-vacuum pressure too high</li> <li>– Ambient temperature too high</li> </ul> </li> </ul>	<ul style="list-style-type: none"> <li>• Check backing pump function</li> <li>• Check seals</li> <li>• Seek leak and repair</li> <li>• Reduce process gas feed</li> <li>• Check bearings (noisy ?); Request PFEIFFER to replace</li> <li>• Extend run-up phase setting time</li> <li>• Ensure free flow</li> <li>• Ensure adequate air supply</li> <li>• Reduce fore-vacuum pressure</li> <li>• Reduce ambient temperature</li> </ul>
Pump doesn't attain final pressure	<ul style="list-style-type: none"> <li>• Pump dirty</li> <li>• Leak in vacuum chamber, lines or pump</li> </ul>	<ul style="list-style-type: none"> <li>• Bake out pump</li> <li>• If seriously contaminated: Request PFEIFFER to clean</li> <li>• Seek leak, starting with vacuum chamber</li> <li>• Repair leak</li> </ul>
Unusual operating noises	<ul style="list-style-type: none"> <li>• Bearings damaged</li> <li>• Rotor damaged</li> <li>• Splinter shield (if fitted) not seated firmly</li> </ul>	<ul style="list-style-type: none"> <li>• Inform PFEIFFER of need for repair</li> <li>• Inform PFEIFFER of need for repair</li> <li>• Check splinter shield: Press clamping lugs away from each other (see Section 3.2.)</li> </ul>

## 6. Maintenance

### Important:

No liability for personal injury nor material damage will be accepted for damages and operational interruptions which have been caused by improper maintenance; in addition, all guarantees become invalid.

You can replace the lubricant reservoir yourself (see Section 6.1.).

Your pump can be cleaned on the spot if it is not very dirty.

Your local PFEIFFER Center can advise you regarding cleaning procedures and any other maintenance and service work which might be necessary.

### 6.1. Replacing The Lubricant Reservoir

Replace the lubricant reservoir at least once every year. Where extreme operating or unclean processes are involved please get in touch with your PFEIFFER Center for advice.

- ➔ Switch off turbopump, vent to atmospheric pressure (see Section 4.4.) and allow to cool as necessary.
- ➔ If necessary remove the turbopump from the system.
- ➔ Using a broad screwdriver unscrew the locking cap 90 from the underside of the pump; be careful with the O-ring 91.
- ➔ Lever out the lubricant reservoir with the help of two screwdrivers.



Lubricant reservoirs can contain toxic substances from the media pumped. Dispose of lubricant reservoirs in accordance with local regulations.

#### Remove locking cap and take out lubricant reservoir

- 90 Locking cap
- 91 O-ring
- 92 Lubricant reservoir
- 93 O-ring

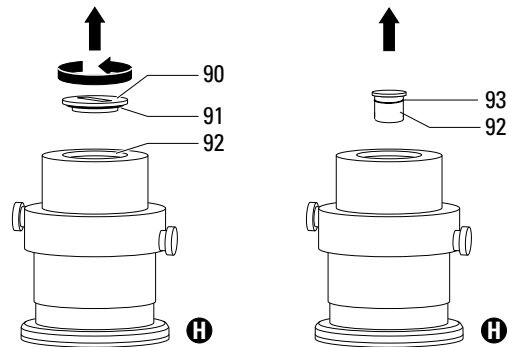

- ➔ Remove dirt from the pump and locking cap with a clean, fluff-free cloth.
- ➔ Insert new lubricant reservoir 92, which comes filled with Lubricant TL 011, up to the O-ring 93.
- ➔ Screw in locking cap 90 with O-ring 91. The locking cap will bring the lubricant reservoir into the correct axial position.

## 7. Service

### Do make use of our service facilities

In the event that repairs are necessary a number of options are available to you to ensure any system down time is kept to a minimum:

- Have the pump repaired on the spot by our Service Engineers;
- Return the pump to the manufacturer for repairs;
- Replace the pump.

Local PFEIFFER representatives can provide full details.

### Before returning:

- ➔ Please attach a clearly visible notice "Free of harmful substances" (both on the unit and also on the delivery note and any accompanying letters).

"Harmful substances" are defined in the current, local regulations and in the U.S.A. as "materials in accordance with the Code of Federal Regulations (CFR) 49 Part 173.240 Definition and Preparation".

We will carry out the decontamination and invoice this work to you if you have not attached this note. This also applies where the operator does not have the facilities to carry out the decontamination work. Units which are contaminated microbiologically, explosively or radioactively cannot be accepted as a matter of principle.

### Fill out the contamination declaration

- ➔ In every case the "Contamination Declaration" must be completed diligently and truthfully.
- ➔ A copy of the completed declaration must accompany the unit: any additional copies must be sent to your local PFEIFFER Center.

Please get in touch with your local PFEIFFER representatives if there are any questions regarding contamination.



Decontaminate units before returning or possible disposal. Do not return any units which are microbiologically, explosively or radioactively contaminated.

### Returning contaminated units

If contaminated have to be returned for maintenance/repair, the following instructions concerning shipping must be followed:

- ➔ Neutralise the pump by flushing with nitrogen or dry air.
- ➔ Seal all openings to the air.
- ➔ Seal pump or unit in suitable protective foil.
- ➔ Ship units only in appropriate transport containers.

### Please note:

Repair orders are carried out according to our general conditions of sale and supply. If repairs are necessary, please send the unit to your nearest PFEIFFER Service Center.

### Contact addresses and service hotline

Contact addresses and service hotlines can be found on the back cover of these operating instructions.

## 8. Technical Data

Feature	Unit	TMH 064	TMH 064 TMU 064	TMH 065	TMH 065 TMU 065
Connection nominal diameter Inlet		DN 40 ISO-KF	DN 63 ISO-KF DN 63 CF-F	DN 40 ISO-KF	DN 63 ISO-KF DN 63 CF-F
Outlet Venting connection		DN 16 ISO-KF/G 1/4" G 1/8"		DN 16 ISO-KF/G 1/4" G 1/8"	
Max. permissible rotor temperature	°C	90		90	
Permissible heat radiation power	W	4		4	
Electronic Drive Unit		TCP 015 <sup>1)</sup>		TCP 015 <sup>1)</sup>	
Nominal rotation speed	1/min	90 000		90 000	
Standby rotation speed	1/min	60 000		60 000	
Run-up time (up to 90% rated rotation speed)	min	2,5		3	
Noise level	dB (A)	< 50		< 50	
Final pressure, backing pump	mbar	≤ 5		≤ 5	
Volume flow rate for:					
Nitrogen N <sub>2</sub>	l/s	30	53	30	56
Helium He	l/s	40	42	40	48
Hydrogen H <sub>2</sub>	l/s	20	31	34	36
Compressen ratio for:					
N <sub>2</sub>		> 10 <sup>9</sup>		> 10 <sup>10</sup>	
He		7 · 10 <sup>4</sup>		1 · 10 <sup>7</sup>	
H <sub>2</sub>		4 · 10 <sup>3</sup>		1 · 10 <sup>5</sup>	
Max. fore-vacuum pressure					
N <sub>2</sub>	mbar	14		18	
He	mbar	10		15	
H <sub>2</sub>	mbar	6		8	
Max. gas throughput <sup>2)</sup>					
N <sub>2</sub>	mbar l/s	1,1		0,8	
He	mbar l/s	1,5		1,0	
H <sub>2</sub>	mbar l/s	1		1,2	
Final pressure <sup>3)</sup>					
with diaphragm vacuum pump	mbar	< 1 · 10 <sup>-8</sup>		< 1 · 10 <sup>-9</sup>	
with rotary vane vacuum pump	mbar	< 2 · 10 <sup>-10</sup>		< 1 · 10 <sup>-10</sup>	
Lubricant		TL 011		TL 011	
Cooling type, standard		convection		convection	
Cooling water consumption with water at 15 °C	l/h	15		15	
Cooling water temperature	°C	5 - 25		5 - 25	
Permissible ambient temperature with air cooling	°C	0 - 35		0 - 35	
Heating power consumption	W	40		40	
Weight	kg	3.6	3.6/3.8	4.7	4.7/5.1
Permissible magnetic field	mT	4		4	

1) Option: TCP 121, TCP 380 .

2) Measured with rotary vane vacuum pump 1.5 m<sup>3</sup>/h.

3) In accordance with DIN 28 428 the final pressure of a turbomolecular pump is that pressure which is attained in a measuring dome 48 hours after baking out.

## 8.1. Dimensions Diagram

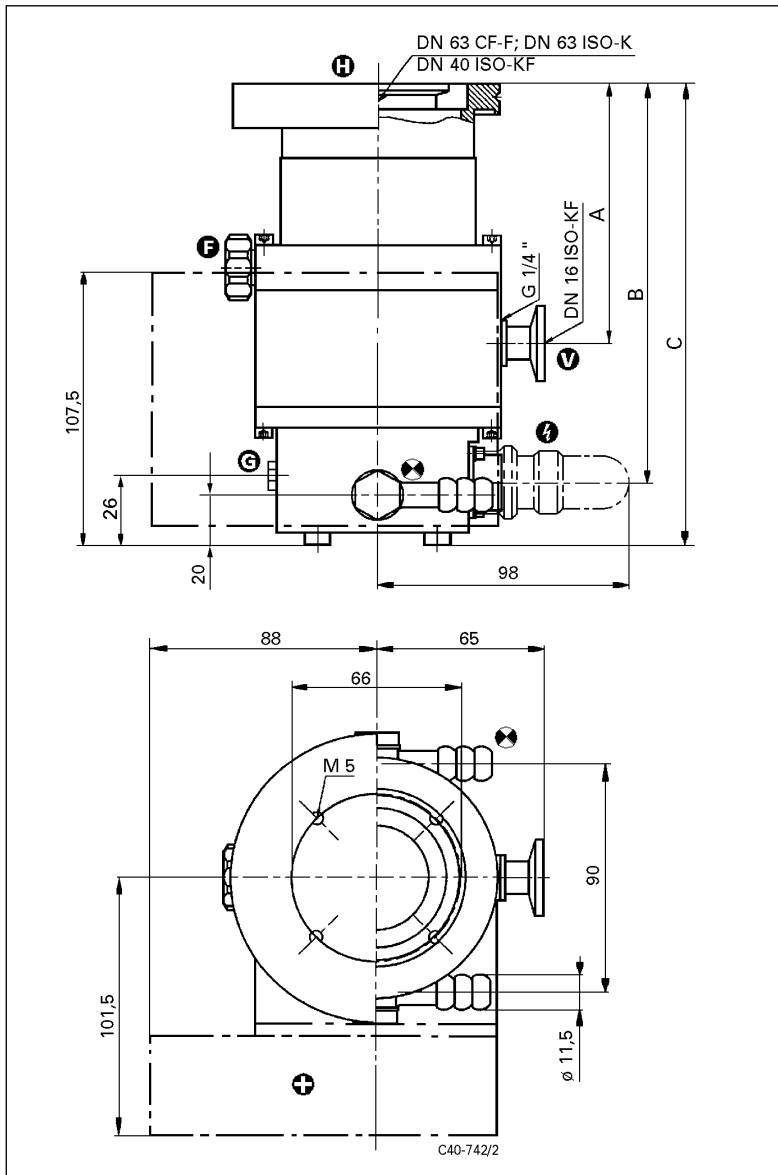

	TMH/TMU 064	TMH/TMU 065
<b>A</b>	102.5	126.5
<b>B</b>	157	182
<b>C</b>	182	207

## 9. Spare Parts

Pos.	Description	Pieces	Size	Number	Comments	Ordering Quantity
	<b>Spare part TMH/U 064; TMH/U 065</b>					
	Set of seals	1		PM 063 187 -T		
6	Rubber food	4		P 3695 700 ZD		
17	QUAD-ring	1	VI 10,82x1,78	P 4081 630 C		
15	O-ring	1	6 x 2,2	P 4070 088 PV		
92	Lubricant reservoir (with locking cap 90 and O-ring 91)	1		PM 073 073-T		
	<b>Spare parts, air cooling</b>					
36	Fan	1	110 V	PM 006 209 -R		
		1	230 V	PM 006 229 -R		
36a	Buffer	3		P 3695 702 QE		
	<b>Spare part, water cooling</b>					
16	USIT-ring	4	MS-NBR U 12,7/18x1,5	P 3529 142		
18	Hose nipple	2		PM 003 025		
19	Hollow screw	4		N 4140 837 A		

Spare parts TMH/TMU 064, TMH/TMU 065

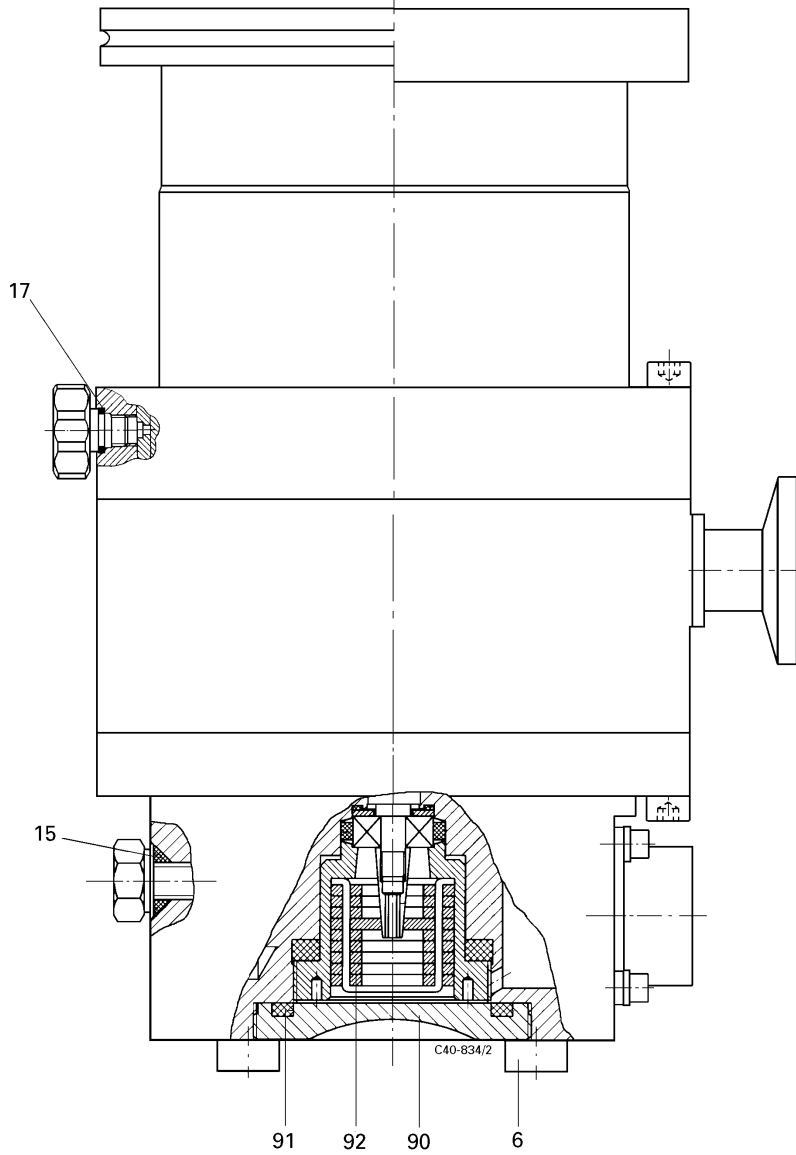

Spare parts, water cooling

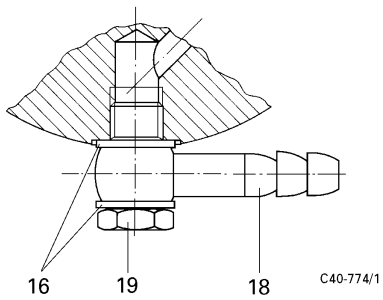

Spare parts, air cooling

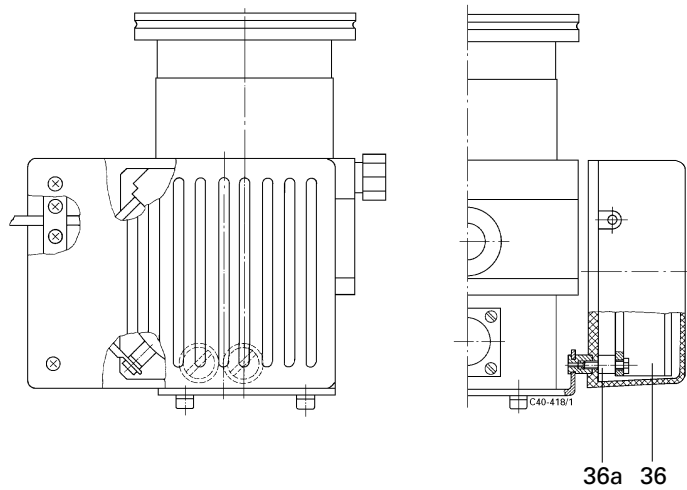



## Declaration of Contamination of Vacuum Equipment and Components

The repair and/or service of vacuum components will only be carried out if a correctly completed declaration has been submitted. Non-completion will result in delay.

The manufacturer could refuse to accept any equipment without a declaration.

**This declaration can only be completed and signed by authorised and qualified staff:**

**1. Description of component:**

- Equipment type/model: \_\_\_\_\_
- Code No.: \_\_\_\_\_
- Serial No.: \_\_\_\_\_
- Invoice No.: \_\_\_\_\_
- Delivery Date: \_\_\_\_\_

**2. Reason for return:**

\_\_\_\_\_

\_\_\_\_\_

\_\_\_\_\_

\_\_\_\_\_

**3. Equipment condition**

- Has the equipment been used?  
yes  no
- What type of pump oil was used?  
\_\_\_\_\_
- Is the equipment free from potentially harmful substances?  
yes  (go to section 5)  
no  (go to section 4)

**4. Process related contamination of equipment**

- toxic yes  no
- corrosive yes  no
- microbiological hazard\*) yes  no
- explosive\*) yes  no
- radioactive\*) yes  no
- other harmful substances yes  no

\*) We will not accept delivery of any equipment that has been radioactively or microbiologically contaminated without written evidence of decontamination!

Please list all substances, gases and by-products which may have come into contact with the equipment:

Tradename Product name Manufacturer	Chemical name (or Symbol)	Danger class	Precautions associated with substance	Action if spillage or human contact
1.				
2.				
3.				
4.				
5.				

### 5. Legally Binding Declaration

I hereby declare that the information supplied on this form is complete and accurate. The despatch of equipment will be in accordance with the appropriate regulations covering Packaging, Transportation and Labelling of Dangerous Substances.

Name of Organisation: \_\_\_\_\_

Address: \_\_\_\_\_ Post code: \_\_\_\_\_

Tel.: \_\_\_\_\_

Fax: \_\_\_\_\_ Telex: \_\_\_\_\_

Name: \_\_\_\_\_

Job title: \_\_\_\_\_

Date: \_\_\_\_\_ Company stamp: \_\_\_\_\_

Legally binding signature: \_\_\_\_\_

⇒ **DE, AT****Herstellereklärung im Sinne folgender EU-Richtlinien:**

- **Maschinen 89/392/EWG**
- **Elektromagnetische Verträglichkeit 89/336/EWG**
- **Niederspannung 73/23/EWG**

Hiermit erklären wir, daß das unten aufgeführte Produkt zum Einbau in eine Maschine bestimmt ist und daß deren Inbetriebnahme so lange untersagt ist, bis festgestellt wurde, daß das Endprodukt den Bestimmungen der EU-Richtlinie 89/392/EWG, Anhang II B entspricht.

Wir bestätigen Konformität mit der EU-Richtlinie über elektromagnetische Verträglichkeit 89/336/EWG und der EU-Niederspannungsrichtlinie 73/23/EWG. Die angewandten Richtlinien, harmonisierten Normen, nationalen Normen und Spezifikationen sind unten aufgeführt.

⇒ **GB, IE****Manufacturer's declaration pursuant to the following EU directives:**

- **Machinery Directive 89/392/EEC**
- **Electromagnetic Compatibility Directive 89/336/EEC**
- **Low Voltage Directive 73/23/EEC**

We hereby certify that the product specified below is intended for installation in a machine which is forbidden to be put into operation until such time as it has been determined that the end product is in accordance with the provision of EU Directive 89/392/EEC, Annex II B.

We certify conformity with EU Electromagnetic Compatibility Directive 89/336/EEC and EU Low Voltage Directive 73/23/EEC.

The guidelines, harmonized standards, national standards and specifications which have been applied are listed below.

⇒ **BE, FR****Déclaration du constructeur conformément aux directives CE suivantes:**

- **directive machine CE 89/392/CEE**
- **directive CE 89/336/CEE concernant la compatibilité électromagnétique**
- **directive CE 73/23/CEE concernant la basse tension**

Nous déclarons par la présente que le produit mentionné ci-dessous est prévu pour le montage sur une machine et que sa mise en service est interdite tant qu'il n'a pas été déterminé que le produit final répond bien aux dispositions de la directive CE 89/392/CEE, appendice II B.

Nous confirmons la conformité du produit avec la directive CE 89/336/CEE concernant la compatibilité électromagnétique et la directive CE 73/23/CEE concernant la basse tension. Les directives appliquées, normes harmonisées et les normes et spécifications nationales appliquées figurent ci-dessous.

⇒ **IT****Dichiarazione del costruttore ai sensi delle seguenti direttive UE:**

- **Macchinari 89/392/CEE**
- **Compatibilità elettromagnetica 89/336/CEE**
- **Bassa tensione 73/23/CEE**

Si dichiara che il prodotto qui menzionato è destinato al montaggio in una macchina e che la sua messa in funzione è vietata sin quando non è stato accertato che il prodotto finale non rispetta le disposizioni della direttiva UE 89/392/CEE, Appendice II B.

Attestiamo la conformità con la direttiva UE sulla compatibilità elettromagnetica 89/336/CEE e la direttiva UE sulla bassa tensione 73/23/CEE.

Sono riportate in basso le direttive applicate, le norme standardizzate nonché le norme e le specifiche nazionali utilizzate.

⇒ **ES****Declaración del fabricante al tenor de las siguientes Directivas de la UE:**

- **Maquinarias 89/392/MCE**
- **Compatibilidad Electromagnética 89/336/MCE**
- **Baja Tensión 73/23/MCE**

Por la presente declaramos que el producto mencionado más abajo está previsto para ser incorporado en una máquina y que la puesta en servicio de la misma queda prohibida en tanto que no se haya verificado que el producto final concuerda con las disposiciones resultantes de la Directiva 89/392/MCE de la UE, Apéndice II B.

De nuestra parte certificamos la conformidad con la Directiva 89/336/MCE de la UE sobre Compatibilidad Electromagnética y la Directiva 73/23/MCE de la UE sobre Baja Tensión.

Las directivas aplicadas, normas armonizadas y las normas y especificaciones nacionales aplicadas se mencionan abajo.

⇒ **NL****Verklaring van de fabrikant in de zin van de volgende EU-richtlijnen:**

- **machinerichtlijn 89/392/EEG**
- **richtlijn over elektromagnetische compatibiliteit 89/336/EEG**
- **richtlijn over laagspanning 73/23/EEG**

Hiermee verklaren wij dat het hieronder genoemde product is bedoeld om te worden ingebouwd in een machine en dat de ingebruikneming hiervan zolang verboden is, totdat is vastgesteld dat het eindproduct voldoet aan de bepalingen van EU-richtlijn 89/392/EEG, appendix II B.

Wij bevestigen de conformiteit met de EU-richtlijn over elektromagnetische compatibiliteit 89/336/EEG en de EEG-richtlijn over laagspanning 73/23/EEG

De toegepaste richtlijnen, geharmoniseerde normen en de toegepaste nationale normen en specificaties zijn hierna aangegeven.

⇒ **DK****Producenterklæring i henhold til følgende EU-direktiver:**

- **Maskiner 89/392/EWG**
- **Elektromagnetisk kompatibilitet 89/336/EWG**
- **Lavspænding 73/23/EWG**

Hermed erklærer vi, at det nedenstående produkt er beregnet til indbygning i en maskine og at dennes idriftsættelse er forbudt, indtil det er fastslået, at slutproduktet er i overensstemmelse med EU-direktiv 89/392/EWG tillæg II B.

Vi attesterer konformitet med EU-direktiv vedrørende elektromagnetisk kompatibilitet 89/336/EWG og med EU-lavspændingsdirektiv 73/23/EWG.

De anvendte direktiver, harmoniserede standarder og de anvendte nationale standarder og specifikationer er angivet nedenfor.



**Tillverkarens förklaring enligt följande EG-direktiv:**

- Maskindirektiv 89/392/EEC
- Elektromagnetisk tolerans 89/336/EEC
- Lågspänning 73/23/EEC

Härmed förklarar vi, att den nedan nämnda produkten är avsedd för inmontering i en maskin och att denna maskin inte får tas i drift förrän det har konstaterats, att slutprodukten stämmer överens med EG's direktiv 89/392/EEC, annex II B.

Vi bekräftar konformitet med EG's-direktiv om elektromagnetisk tolerans 89/336/EEC och EG's lågspänningsdirektiv 73/23/EEC.

De riktlinjer, anpassade standarder, nationella standarder och specifikationer som har blivit accepterade, anges här nedan.



**Valmistajan vakuutus seuraavien EU-direktiivien mukaisesti:**

- konedirektiivi 89/392/ETY
- sähkömagneettinen siedettävyyys 89/336/ETY
- pienjännite 73/23/ETY

Vakuutamme täten, että allamainittu tuote on tarkoitettu asennettavaksi koneeseen ja sen käyttöönotto on kielletty kunnes on todettu, että lopullinen tuote vastaa EU-direktiivin 89/392/ETY vaatimuksia.

Vahvistamme vaatimustenmukaisuuden EU-direktiivin sähkömagneettinen siedettävyyys 89/336/ETY ja EU-pienjännitedirektiivin 73/23/ETY kanssa.

Soveltamamme suuntaviitat, harmonisoidut standardit, kansalliset standardit ja rakennemääräykset on lueteltu alempana.



**Declaração do fabricante, de acordo com as seguintes Directivas CE:**

- Máquinas, na redacção 89/392/CEE
- Compatibilidade electromagnética, na redacção 89/336/CEE
- Baixa tensão, na redacção 73/23/CEE

Com a presente, declaramos que o produto abaixo indicado se destina à montagem numa máquina e que é proibida a colocação em serviço da mesma antes de se ter declarado, que o produto final está em conformidade com o disposto na Directiva CE, na redacção 89/392/CEE, Apêndice II B.

Certificamos haver conformidade com o disposto na Directiva CE sobre compatibilidade electromagnética, na redacção 89/336/CEE, e o disposto na Directiva CE sobre baixa tensão, na redacção 73/23/CEE.

Abaixo, dá-se indicação das directivas aplicadas, das normas harmonizadas e das normas e especificações aplicadas no respectivo país.



Δήλωση κατασκευαστή κατά το νόμο των εθνικών οδηγιών της ΕΕ:

- περί μηχανών 89/392/Ε.Ο.Κ.
- περί ηλεκτρομαγνητικής συμβατότητας 89/336/Ε.Ο.Κ.
- περί καμής τάσης 73/23/Ε.Ο.Κ.

Με την παρούσα δήλωση βεβαιώνουμε ότι το κατωτέρω αναφερόμενο προϊόν προορίζεται για την προσαρμογή σε μία άλλη μηχανή, και ότι η έναρξη λειτουργίας της απονέμεται, μέχρις ότου διαπιστωθεί, ότι το συνολικό συγκρότημα ανταποκρίνεται στους ισχύοντες κανονισμούς της οδηγίας της ΕΕ 89/392/Ε.Ο.Κ., παράρτημα Β Β.

Οι εφαρμοσθέντες κανονισμοί, οι εναρμονισμένες προδιαγραφές και οι εφαρμοσθείσες εθνικές προδιαγραφές και τεχνικές προδιαγραφές αναφέρονται κατωτέρω.

Produkt/Product/Produit/Prodotto/Producto/Produkt/Produkt/Produto/ Προϊόν:

**TMH 064 / TMU 064**  
**TMH 065 / TMU 065**

Angewendete Richtlinien, harmonisierte Normen und angewendete, nationale Normen in Sprachen und Spezifikationen:

Guidelines, harmonised standards, national standards in languages and specifications which have been applied:

Les directives appliquées, normes harmonisées et les normes nationales appliquées en langues et spécifications:

Directive applicate, norme standardizzate e norme nazionali utilizzate in lingue e specifiche:

Directivas aplicadas, normas armonizadas y normas nacionales aplicadas en idiomas y especificaciones:

Toegepaste richtlijnen, geharmoniseerde normen en toegepaste nationale normen met betrekking tot talen en specificaties:

Anvendte direktiver, harmoniserede standarder og de anvendte nationale standarder med sprog og specifikationer:

Directivas aplicadas, normas harmonizadas e normas aplicadas na linguagem e nas especificações do respectivo país:

Εφαρμοσθέντες κανονισμοί, εναρμονισμένες προδιαγραφές και εφαρμοσθείσες εθνικές προδιαγραφές σε γλώσσες και τεχνικές προδιαγραφές:

**EN 292-1**                      **EN 294**                      **EN 1012-2**  
**EN 292-2**                      **EN 61 010**

Unterschriften/Signatures/Signature/Firme/Firmas/Handtekening/Underskrifter/Underskrift/ Allekirjoitukset/Assinaturas/ Υπογραφές:

Geschäftsführer (W. Dondorf)

Managing Director

Gérant d'affaires

Gerente

Διευθύνων Σύμβουλος

Administrerende Direktør

Verkställande Direktör

Directeur